



35kW¹ STANDBY GENERATOR

BRIGGS & STRATTON® THE SMART CHOICE

Durable backup power for businesses and luxury homes. Help eliminate losses from power outages with a Briggs & Stratton® Commercial Standby Generator.



FORTRESS™

Introducing our dealer exclusive line. Available at your local Briggs & Stratton Dealer with these great features:

- The industry's most comprehensive warranty²
- Block heater keeps engine warm for easy starting in cold weather



Corrosion Resistant Aluminum Enclosure

- Durable enclosures are built to last, protecting against extreme weather conditions and corrosion

Easy to Service

- Convenient internal swing open doors allow you to easily access the engine; no more taking apart the bolted finger guards, saving you precious time and the hassle of disassembly

Quality Clean Power

- Ensures your electronics are safely powered

Durable Industrial Engine

- Found in industrial applications, the premium industrial 1,800 RPM engine provides strong, reliable power without giving up quiet operation or durability

Custom Built Options

- A complete line of standby generators for commercial applications with multiple voltage configurations and controller options

NFPA 110 Capable

- Suitable for NFPA 110 applications when installed with required NFPA 110 accessories and installation methods



GENERATOR SET RATINGS

MODEL	VOLTAGE	POWER FACTOR	PHASE	HZ	BREAKER	LIQUID PROPANE		NATURAL GAS		CONTROLLER
						LP KW ¹	LP AMPS	NG KW ¹	NG AMPS	
Fortress 076830	120/240	1	1	60	175	35	146	32	133	Briggs & Stratton
Briggs & Stratton 076330	120/240	1	1	60	175	35	146	32	133	Briggs & Stratton
Briggs & Stratton 076131	120/208	0.8	3	60	150	35	121	32	111	InteliNano
Briggs & Stratton 076133	120/240	0.8	3	60	125	35	105	32	96	InteliNano
Briggs & Stratton 076135	277/480	0.8	3	60	60	35	53	32	48	InteliNano
Briggs & Stratton 076331	120/208	0.8	3	60	150	35	121	32	111	InteliLite
Briggs & Stratton 076333	120/240	0.8	3	60	125	35	105	32	96	InteliLite
Briggs & Stratton 076335	277/480	0.8	3	60	60	35	53	32	48	InteliLite

¹ This generator is rated in accordance with UL (Underwriters Laboratories) 2200 (stationary engine generator assemblies) and CSA (Canadian Standards Association) standard C22.2 No. 100-14 (motors and generators).

² Warranty details available at www.briggsandstratton.com



ENGINE SPECIFICATIONS

ENGINE	
Engine Model	4.3L Industrial Powertrain
Engine Type	6 Cylinder, 4-Cycle
Engine Speed (RPM)	1800
Engine Fuel	Liquid Propane Vapor (LPV) or Natural Gas (NG)
Induction System	Naturally Aspirated
Air Filter Type	Dry
Displacement (ltr / cc)	4.3 / 4294
Freq Reg NL to FL	Isochronous
Block Heater	Included
Governor Type	Electronic
Frequency Regulation	+ / -.5%
Starter Motor Rated Voltage	12 Volt
Battery (volts dc / cca)	12 Volt / 775
ENGINE OUTPUT DERATINGS - STANDBY	
Rated Temp	104°F / 40°C
Rated Altitude	Sea Level
Max Altitude	15,000 ft
Temperature Derate	1% for each 10°F (5.6°C) above rated temp
Altitude Derate	3% / 1000 ft

LUBRICATION	
Oil Capacity (qts / ltrs)	4.5 / 4.3
Oil Capacity with Filter (qts / ltr)	5.0 / 4.7
Oil Filter (quantity / type)	1 / Spin-on
Lubrication System	Full Pressure
Recommended Oil	API GF-4 10W30

ALTERNATOR SPECS	
Type	4-Pole, Rotating Field
Voltage Regulator	Solid State, Volts / Hz
Insulation (rating)	Class H
Designed Temperature Rise Limit	125°C
Bearing (quantity / type)	1 / Sealed
Voltage Reg NL to FL	+ / -1.0%
Frequency Compensation	8V / Hz Voltage Drop Below 55 Hz

ENGINE FUEL SYSTEM SPECIFICATIONS	
Recommended Fuel	
LP min LHV (btu / ft ³)	2260
NG min LHV (btu / ft ³)	890
Fuel Supply Pressure (in-H ₂ O)	7-11 (at full load)
Fuel Supply Line at Engine (npt)	1"

OPERATIONS

	FUEL CONSUMPTION ³			
	50% Load		100% Load	
Liquid Propane	102 ft ³ / hr	2.8 gal / hr	160 ft ³ / hr	4.4 gal / hr
Natural Gas	253 ft ³ / hr	253,000 btu / hr	394 ft ³ / hr	394,000 btu / hr

SOUND RATING AT 7 METERS PER ISO 3744
67 dBA

Lowest measurement of 12 microphones around generator. Sound level measurement at other locations around generator may be different depending upon installation configuration.

¹ This generator is rated in accordance with UL (Underwriters Laboratories) 2200 (stationary engine generator assemblies) and CSA (Canadian Standards Association) standard C22.2 No. 100-14 (motors and generators).

³ Fuel consumption rates are estimated based on normal operating conditions. Generator operation may be greatly affected by elevation and the cycling operation of multiple electrical appliances – fuel flow rates may vary depending on these factors.



ADDITIONAL INFORMATION

OTHER FEATURES

Enclosure Material Corrosion-Resistant Aluminum

WEIGHT AND DIMENSIONS

Assembled Weight (lbs / kg) 1540 / 700

Overall Dimensions (in) 91 x 39.4 x 41

Packaged Weight (lbs) 1940 / 880

Packaged Dimensions (in) 104 x 51 x 48

BATTERY CHARGERS FOR INTELINANO/INTELILITE

Standard 6279

NFPA 110 6339

CERTIFICATION

CARB Compliant Yes

UL Listed to 2200 Yes

cUL Listed to CSA 22.2 NO 100-04 Yes

NEMA Compliant Yes

EPA Certified Fuel System Yes

AVAILABLE ACCESSORIES

Battery Warmer 6343

Basic Wireless Monitor 6229

InfoHub 6260

Remote Status Monitor 6144

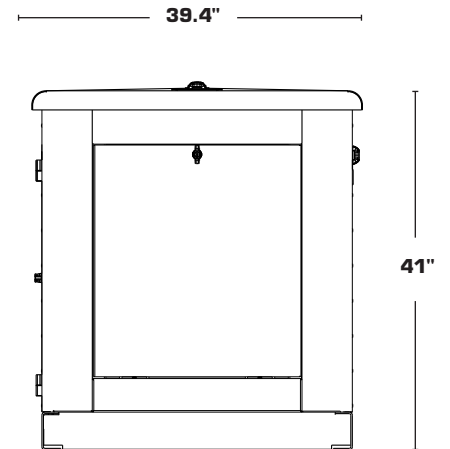
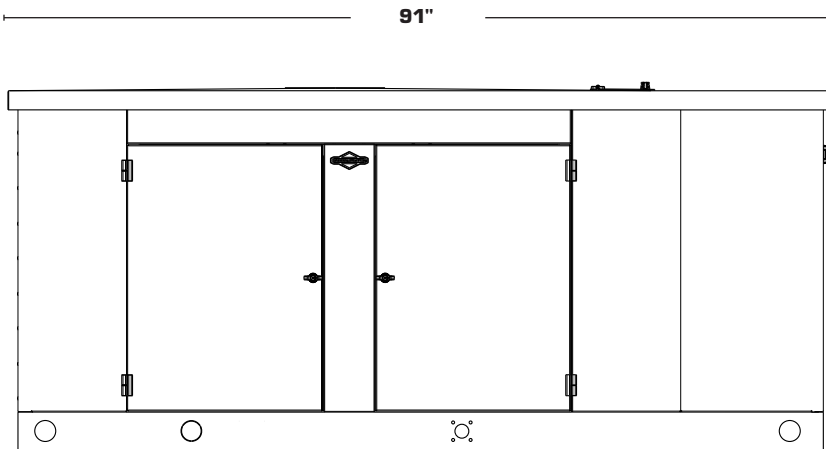

¹ This generator is rated in accordance with UL (Underwriters Laboratories) 2200 (stationary engine generator assemblies) and CSA (Canadian Standards Association) standard C22.2 No. 100-14 (motors and generators).



STANDARD CONTROLLERS



Briggs & Stratton® Standard AMF Controller for Single Phase

- User-friendly control panel for troubleshooting
- Conveniently monitors diagnostic conditions, displays system fault codes and sets weekly exercise cycle
- Easy-to-read alpha-numeric scrolling display
- Single-phase generator application only
- UL recognized



InteliNano (NT) Controller for 3-Phase

- 3-phase generator application only
- Large graphical display
- 3-phase voltage sensing
- "Zero" power consumption mode
- Easy installation and user-friendly operation
- 10 event history log
- USB communication interface
- Six binary inputs, three analog inputs
- Two low-current and two high-current binary outputs
- UL recognized

OPTIONAL CONTROLLERS



InteliLite (NT) Controller

- 3-phase and single-phase generator applications
- 3-phase voltage sensing
- Current sensing
- Seven binary inputs, three analog inputs
- Seven binary outputs
- Additional input/output accessories available
- Various communication modules available
- Remote control and monitoring capabilities
- UL recognized



InteliLite Accessories (sold separately)

- Remote Annunciator, NFPA 110 Compliant (6334)
- Remote Display (6353)
- IL-NT GPRS (6354)
- IB-LITE (6355)
- IL-NT RS232-485 (6356)
- IL-NT S-USB (6357)

¹ This generator is rated in accordance with UL (Underwriters Laboratories) 2200 (stationary engine generator assemblies) and CSA (Canadian Standards Association) standard C22.2 No. 100-14 (motors and generators).



FUEL PIPE SIZE RECOMMENDATION CHART (CAPACITY IN THOUSANDS OF BTU/HOUR)

Natural Gas / Inlet Pressure less than 2 PSI / Pressure Drop 1/2" Water Column / Specific Gravity 0.60

	1/2" pipe capacity	3/4" pipe capacity	1" pipe capacity	1-1/4" pipe capacity	1-1/2" pipe capacity	2" pipe capacity
20' Length ¹	118	247	466	957	1,430	2,760
40' Length ¹	81	170	320	657	985	1,900
60' Length ¹	65	137	257	528	791	1,520
80' Length ¹	56	117	220	452	677	1,300
100' Length ¹	50	104	195	400	600	1,160

Liquid Propane / Inlet Pressure 11" Water Column / Pressure Drop 1/2" Water Column / Specific Gravity 1.50

	1/2" pipe capacity	3/4" pipe capacity	1" pipe capacity	1-1/4" pipe capacity	1-1/2" pipe capacity	2" pipe capacity
20' Length ¹	200	418	788	1,617	2,423	4,666
40' Length ¹	137	287	541	1,111	1,665	3,207
60' Length ¹	110	231	435	892	1,337	2,575
80' Length ¹	101	212	400	821	1,230	2,370
100' Length ¹	101	212	400	821	1,230	2,370

*Total length of piping from outlet of regulator to appliance furthest away.



6 LIMITED WARRANTY²
PARTS, LABOR, TRAVEL

5 LIMITED WARRANTY²
PARTS, LABOR, TRAVEL

MODEL NUMBER	Fortress 076840	Briggs & Stratton 076330
		Briggs & Stratton 076131
		Briggs & Stratton 076133
		Briggs & Stratton 076135
		Briggs & Stratton 076331
		Briggs & Stratton 076333
		Briggs & Stratton 076335

SUPPORT EVERY STEP OF THE WAY

NEED HELP? Just call 800-759-2744

Our technical support team is trained to answer questions on our generators, transfer switches and accessories.

CALL TODAY FOR A FREE IN-HOME ESTIMATE!
800-743-4115

¹ This generator is rated in accordance with UL (Underwriters Laboratories) 2200 (stationary engine generator assemblies) and CSA (Canadian Standards Association) standard C22.2 No. 100-14 (motors and generators).

² Warranty details available at www.briggsandstratton.com

Disclaimer: Not for Prime Power or use where standby systems are legally required, for serious life safety or health hazards, or where lack of power hampers rescue of fire-fighting operations.

BRIGGS & STRATTON

POST OFFICE BOX 702
MILWAUKEE, WI 53201 USA

Copyright ©2016. All rights reserved. BS1007-F - 8/16